



aerospace
climate control
electromechanical
filtration
fluid & gas handling
hydraulics
pneumatics
process control
sealing & shielding



Parker 7321B/ 7322B Series Water Valves

High performance 2-way pilot operated solenoid valves for water, light oils and steam



ENGINEERING YOUR SUCCESS.

Parker 7321B/7322B Series Water Valves

Parker 7321B/7322B 2/2 pilot operated valves is the best solution anywhere a perfect control media such water, steam, and light oils is required.

7321B/7322B Series are diaphragm pilot operated valves and require a minimum differential pressure to operate.

Water is the basic element for human life, and water control makes possible a wide variety of human activities such as irrigation and food production, breeding, water dispensing, energy production, car and tools washing; water is the basic element in many applications like fire-fighting, domestic, plumbing.

Basing on solenoid technology, among the features this product provides a high flow rate, a fast reaction time and a superior reliability in a robust and modern design.

Manual override is available to open and close the valve without electrical supply, as well as speed control option against water hammer effect.

Our 7321B/7322B Water Valves range is usable with the most of our FCDE coil ranges, including ATEX, low power and IP67 electrical parts.



The Species Evolution

Roman Age

Parker Age

Applications

Thanks to the best performances in flow rate, 7321B/7322B Series can be used for many applications with high flow rates and media such as water, hot water and steam. Typical applications can be found in: Plumbing mkt, industrial washing machines, car wash installations, cooling of machine tools, hydrocleaners, autoclaves, irrigation systems, etc...



Benefits

Among the most valuable features you can find in this product:

- Best performances for minimum and maximum operating pressure differential
- Exclusive diaphragm design for a **Superior Flow Rate**, higher than the competition valves with the same dimensional specs and flat diaphragm
- **One of the Fastest** in electrical and hydraulic opening response time
- Modular concept: a wide range of electrical parts increases the versatility of this product
- Robust design: areas under mechanical stress have been studied and oversized
- Manual override control option: valve can be easily activated also when there's no energy supply
- Stainless steel pilot for superior life endurance with special sealing
- Easy access to internal parts, to permit easy and quick maintenance

Introducing Parker 7321B/7322B Series Water Valves

General Description

Parker 7321B/7322B are diaphragm pilot operated solenoid valves and require a minimum differential pressure to operate.

This serie is available in both Normally Closed and Normally Open function: 7321B Serie is a Normally Closed family (closed when de-energised), 7322B Serie is the Normally Open family (Open when de-energised).

Material Specifications

Valve body:	CW617N UNI EN 12165:98 Forged Brass	Spring:	AISI 302 St. Steel
Enclosing tube:	AISI 304 stainless steel	Seals:	NBR (Buna N) - EPDM FKM (Viton)
Plunger:	AISI 430F St. Steel	Shading ring:	Copper

Installation

The valves can be mounted in any position. It is however recommended to install them with the coil in vertical position above the body.

Media

These valves have been developed to achieve the best performances for water, steam, light oils (up to 2°E). Therefore these valves are not usable with gas and air.

We recommend to choose NBR versions for plumbing mkt (max. temp. 90°C), FKM version for water/light oils control applications up to 140°C, EPDM version for superheated water and steam (up to 140°C)

Electrical Parts

A wide range of electrical parts are available for 7321B/7322B Series. The complete offer of electrical parts is shown at pages 18 to 21.

Please consult factory in case you need to verify the compatibility of 7321B/7322B Series with alternative ranges of paper FCDE coils not included in this catalogue.

Please consult also the "How to Order" section at page 22 to select the product configuration which fits your application requirements.

Available Options

Manual Control

Parker 7321B Serie (NC version only) can be ordered with Manual control option. A manual control is used to operate the valve without connecting the coil.

The control consists in a slotted-head screw for a screwdriver and has two possible positions:

Closed: The letter "C" is in the upper position of the screw head (fig.1,2)

Open: The letter "A" is in the upper position of the screw head (fig.1,2)

Standing in its closed position, the valve operates normally when coil is energised/de-energised. Manual and speed control are standard on 2 ½" and 3" versions.

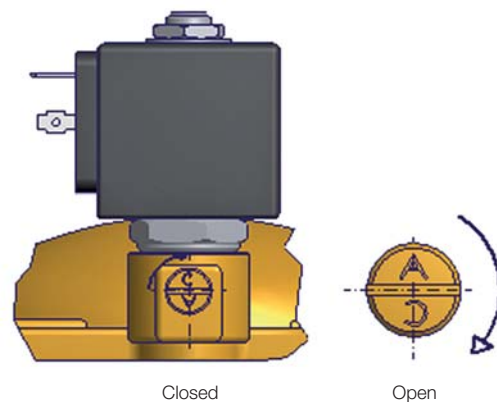

Speed Control Option (Anti-Water Hammer Control)

Parker 7321B Serie (NC version only) can be ordered with Speed control option. The closure time of certain types can be changed by means of the adjusting screw. The latter, by acting as a throttle on the inlet equalisation (pilot) hole of the valve, slows down the closure speed of the valve, thus reducing the water hammer effect.

The regulation range is as follows:

Screw fully open: Max. closure speed

Screw fully closed: Valve always open

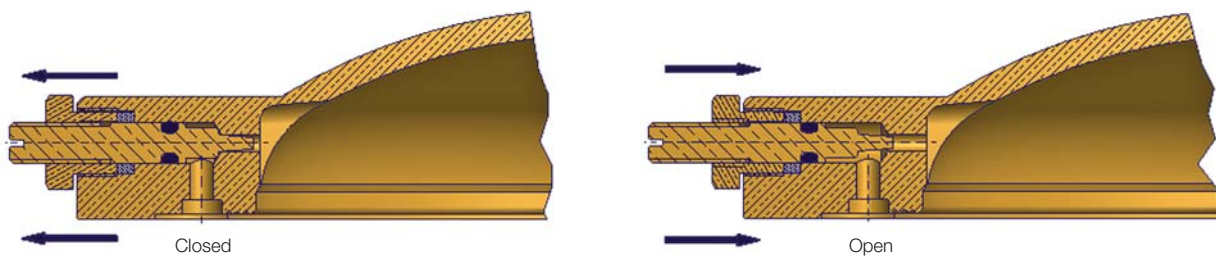

Please consult diagrams at page 6 of this catalogue to find details about shut-off response time with speed control option.



Diagrams of the Closing Times

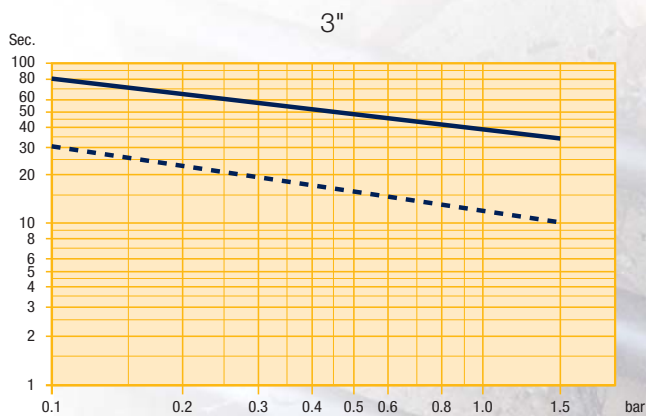
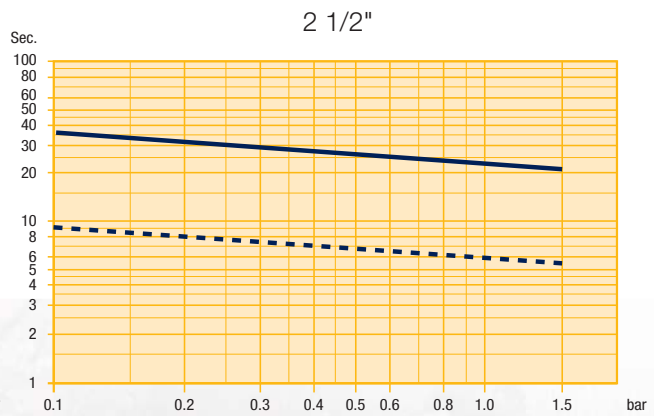
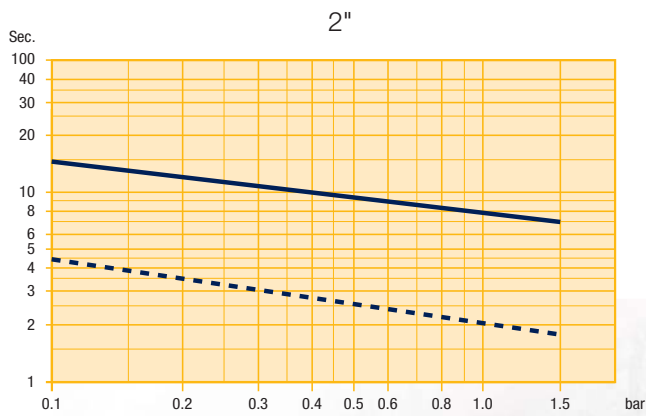
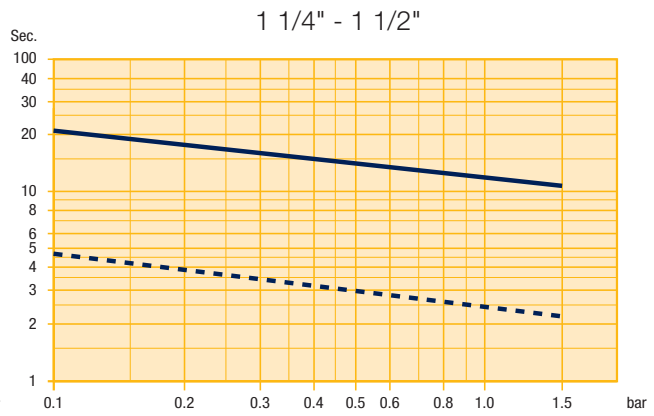
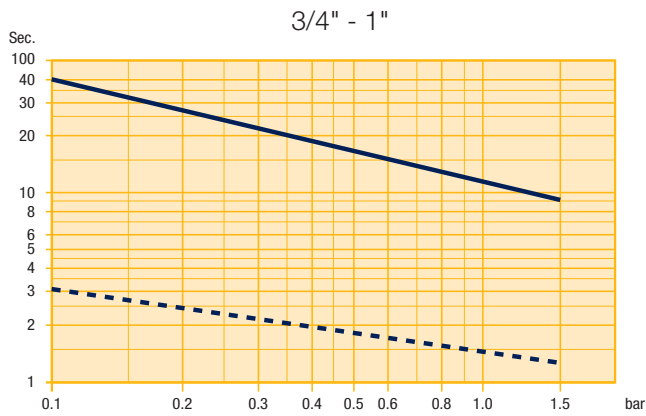

— **Curve 1:** Closing time with adjusting screw open by 1/2 turn
 - - - **Curve 2:** Closing time with adjusting screw completely open

Product availability

7321B/7322B Pressure Vessel

A wide range of configurations for this solenoid valve family is available: port sizes from 3/8" to 3" in brass, with BSPP port threads or with NPT ports, along with a wide range of seal and disc materials ensures that we have a standard valve to fit most applications.

In the table herebelow you might also find an explanation of the general description system for 7321B/7322B Series water valves family.

Description							Reference		
7	3	2	1	B	A	N	x	x	
7									7 000 Operators
	3								Pilot Operated Valve
	2								Direct Lift Operated Valve
	1								Direct Operated Valve
		2							2/2 Ways
			2						Normally Open
			1						Normally Close
				A					Family Name
				B					
				C					
				...					
					I				
					A				1/2"
					C				3/4"
					D				1"
					E				1 1/4"
					F				1 1/2"
					G				2"
					L				2 1/2"
					M				3"
						N			NBR
						V			KKM
						H			EPDM
							0	0	Standard Version
							0	1	Manuel Override
							0	2	Speed Control + MO
							0	6	Speed Control
							9	0	NPT
							9	1	NPT - Manuel Override (MO)
							9	2	NPT - Speed Control + MO
					S	x	x	x	Special versions

Please note:

- Electrical parts available are not included in the description system hereabove which refers to pressure vessel only. You can find electrical parts available at pages 18 to 21.
- Please consult in detail the "How to Order" section at page 22.

2/2 Normally Closed - BSP threads

NBR Seals (Max. Media Temp. 90°C)

Port Size G	Orifice mm	Flow Factors m ³ /h	l/min	Minimum Pressure	Maximum Differential	Weight Kg	Manual Control	Speed Control Pressure	Description	Part Number	Dimensional Drawing
3/8"	13	3.0	50.0	0.1	20	0.55	-	-	7321BIN00	443776W	2
	13	3.0	50.0	0.1	20	0.55	x	-	7321BIN01	443777W	
1/2"	13	3.0	50.0	0.1	20	0.58	-	-	7321BAN00	443779W	2
	13	3.0	50.0	0.1	20	0.58	x	-	7321BAN01	443780W	
3/4"	20	8.4	139.9	0.1	20	1.02	-	-	7321BCN00	443782W	3
	20	8.4	139.9	0.1	10	1.02	x	-	7321BCN01	443783W	
	20	8.4	139.9	0.1	10	1.02	x	x	7321BCN02	443784W	
1"	25	9.6	159.9	0.1	20	1.08	-	-	7321BDN00	443786W	3
	25	9.6	159.9	0.1	10	1.08	x	-	7321BDN01	443787W	
	25	9.6	159.9	0.1	10	1.08	x	x	7321BDN02	443788W	
1 1/4"	35	25.2	419.8	0.1	10	3.15	-	-	7321BEN00	443790W	4
	35	25.2	419.8	0.1	5	3.15	x	-	7321BEN01	443791W	
	35	25.2	419.8	0.1	5	3.15	x	x	7321BEN02	443792W	
1 1/2"	40	30.0	499.8	0.1	10	2.90	-	-	7321BFN00	443794W	4
	40	30.0	499.8	0.1	5	2.90	x	-	7321BFN01	443795W	
	40	30.0	499.8	0.1	5	2.90	x	x	7321BFN02	443796W	
2"	50	37.2	619.8	0.1	10	4.30	-	-	7321BGN00	443798W	4
	50	37.2	619.8	0.1	5	4.30	x	-	7321BGN01	443799W	
	50	37.2	619.8	0.1	5	4.30	x	x	7321BGN02	443800W	
2 1/2"	65	66.0	1099.6	0.2	10	13.60	x	x	7321BLN02	443802W	5
3"	75	80.0	1332.8	0.2	10	11.90	x	x	7321BMN02	443803W	5

Nominal pressure: 25 bar from 1 1/4" to 3" 16 bar

FKM Seals (Max. Media Temp. 140°C)

Port Size G	Orifice mm	Flow Factors m ³ /h	l/min	Minimum Pressure	Maximum Differential	Weight Kg	Manual Control	Speed Control Pressure	Description	Part Number	Dimensional Drawing
3/8"	13	3.0	50.0	0.1	20	0.55	-	-	7321BIV00	444492W	2
1/2"	13	3.0	50.0	0.1	20	0.58	-	-	7321BAV00	444494W	2
3/4"	20	8.4	139.9	0.1	20	1.02	-	-	7321BCV00	444497W	3
1"	25	9.6	159.9	0.1	20	1.08	-	-	7321BDV00	443804W	3

Nominal pressure: 25 bar

EPDM Seals (Max. Media Temp. 140°C)

Port Size G	Orifice mm	Flow Factors m ³ /h	l/min	Minimum Pressure	Maximum Differential	Weight Kg	Manual Control	Speed Control Pressure	Description	Part Number	Dimensional Drawing
3/8"	13	3.0	49.98	0.1	10	0.55	-	-	7321BIH00	443778W	2
1/2"	13	3.0	49.98	0.1	10	0.55	-	-	7321BAH00	443781W	2
3/4"	20	8.4	139.94	0.1	10	1.02	-	-	7321BCH00	443785W	3
1"	25	9.6	159.94	0.1	10	1.08	-	-	7321BDH00	443789W	3
1 1/4"	35	25.2	419.83	0.1	10	3.15	-	-	7321BEH00	443793W	4
1 1/2"	40	30.0	499.80	0.1	10	2.90	-	-	7321BFH00	443797W	4
2"	50	37.2	619.75	0.1	10	4.30	-	-	7321BGH00	443801W	4

Nominal pressure: 25 bar - Max press for steam: 4 bar

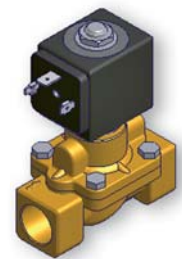
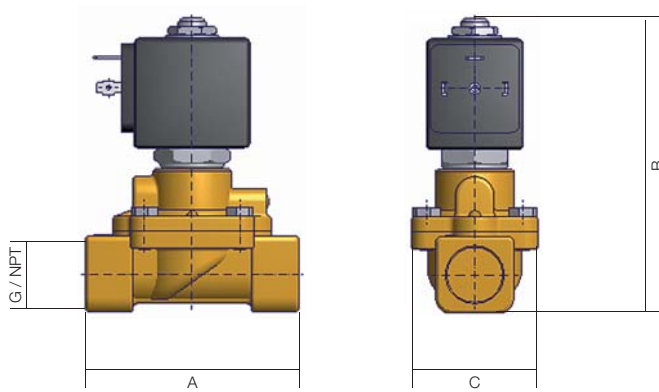

G NTP	A		B		C	
	mm	inch	mm	inch	mm	inch
3/8"	69	2.71	99.5	3.91	40	1.57
1/2"	72	2.83	101.5	3.99	40	1.57

Dimensional Drawing N° 2

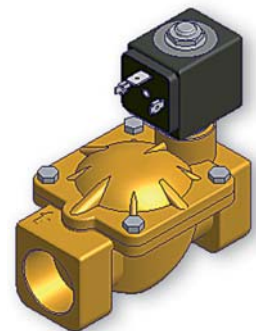
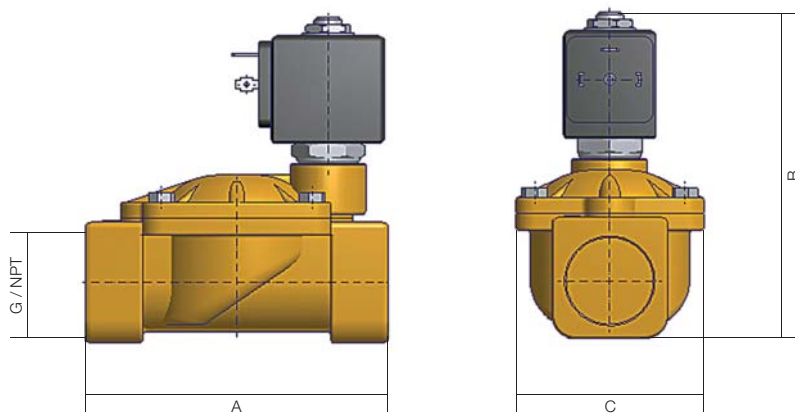

G NTP	A		B		C	
	mm	inch	mm	inch	mm	inch
3/4"	100	3.83	107	4.21	65	2.55
1"	104	4.09	112.5	4.42	65	2.55

Dimensional Drawing N° 3

2/2 Normally Closed - BSP threads

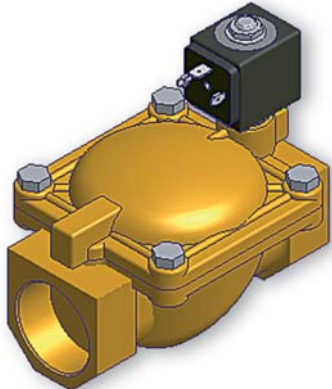
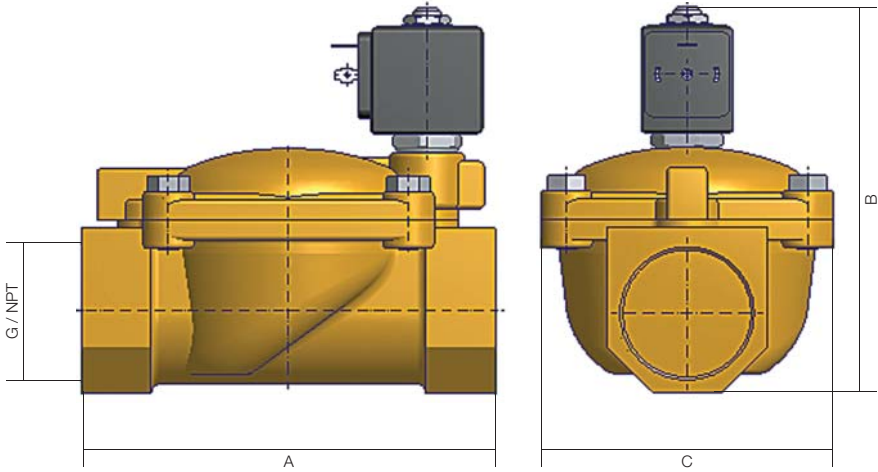

G NTP	A		B		C	
	mm	inch	mm	inch	mm	inch
1-1/4"	145	5.70	134	5.27	102	4.01
1-1/2"	145	5.70	134	5.27	102	4.01
2"	173	6.81	148	5.82	118	4.64

Dimensional Drawing N° 4

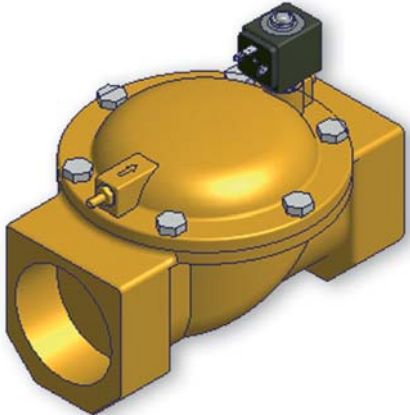
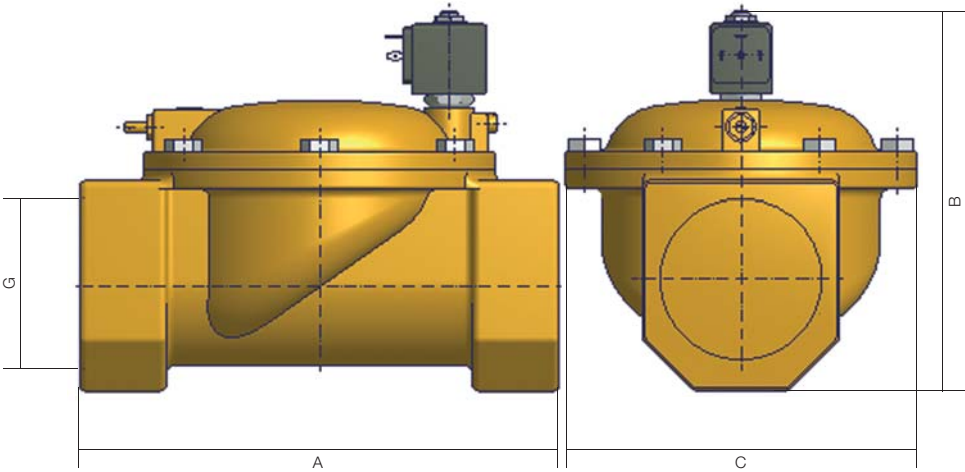

G	A		B		C	
	mm	inch	mm	inch	mm	inch
3/8"	245	-	195	-	184	-
1/2"	250	-	195	-	184	-

Dimensional Drawing N° 5

2/2 Normally Open - BSP threads

NBR Seals (Max. Media Temp. 90°C)

Port Size G	Orifice mm	Flow Factors m ³ /h	l/min	Minimum Pressure	Maximum Differential	Weight Kg	Manual Control	Speed Control Pressure	Description	Part Number	Dimensional Drawing
3/8"	13	3.0	49.98	0.1	20	0.55	-	-	7322BIN00	443805W	6
1/2"	13	3.0	49.98	0.1	20	0.58	-	-	7322BAN00	443806W	6
3/4"	20	8.4	139.94	0.1	20	1.02	-	-	7322BCN00	443807W	7
1"	25	9.6	159.94	0.1	20	1.08	-	-	7322BDN00	443808W	7
1 1/4"	35	25.2	419.83	0.1	10	3.15	-	-	7322BEN00	443809W	8
1 1/2"	40	30.0	499.80	0.1	10	2.90	-	-	7322BFN00	443810W	8
2"	50	37.2	619.75	0.1	10	4.30	-	-	7322BGN00	443811W	8
2 1/2"	65	66.0	1099.56	0.2	10	13.60	-	x	7322BLN06	444513W	9
3"	75	80.0	1332.80	0.2	10	11.90	-	x	7322BMN06	444503W	9

Nominal pressure: 25 bar from 1 1/4" to 3" 16 bar

FKM Seals (Max. Media Temp. 140°C)

Port Size G	Orifice mm	Flow Factors m ³ /h	l/min	Minimum Pressure	Maximum Differential	Weight Kg	Manual Control	Speed Control Pressure	Description	Part Number	Dimensional Drawing
3/8"	13	3.0	49.98	0.1	20	0.55	-	-	7322BIV00	444499W	6
1/2"	13	3.0	49.98	0.1	20	0.58	-	-	7322BAV00	444500W	6
3/4"	20	8.4	139.94	0.1	20	1.02	-	-	7322BCV00	444501W	7
1"	25	9.6	159.94	0.1	20	1.08	-	-	7322BDV00	444502W	7

Nominal pressure: 25 bar from 1 1/4" to 2" 16 bar

EPDM Seals (Max. Media Temp. 140°C)

Port Size G	Orifice mm	Flow Factors m ³ /h	l/min	Minimum Pressure	Maximum Differential	Weight Kg	Manual Control	Speed Control Pressure	Description	Part Number	Dimensional Drawing
3/8"	13	3.0	49.98	0.1	10	0.55	-	-	7322BIH00	444600W	6
1/2"	13	3.0	49.98	0.1	10	0.58	-	-	7322BAH00	444601W	6
3/4"	20	8.4	139.94	0.1	10	1.02	-	-	7322BCH00	444602W	7
1"	25	9.6	159.94	0.1	10	1.08	-	-	7322BDH00	444603W	7
1 1/4"	35	25.2	419.83	0.1	10	3.15	-	-	7322BEH00	444576W	8
1 1/2"	40	30.0	499.80	0.1	10	2.90	-	-	7322BFH00	444604W	8
2"	50	37.2	619.75	0.1	10	4.30	-	-	7322BGH00	444605W	8

Nominal pressure: 25 bar from 1 1/4" to 2" 16 bar

2/2 Normally Open - BSP threads

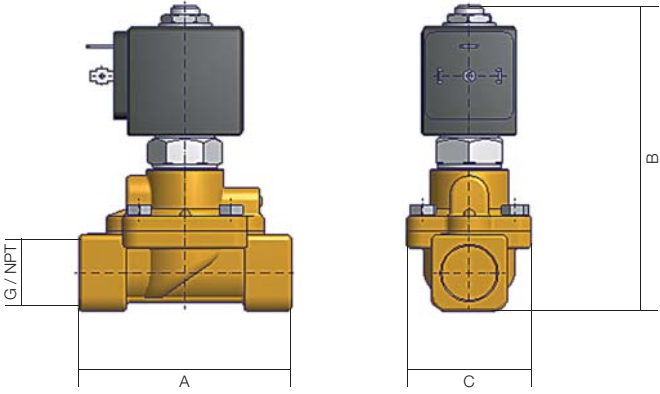

G NTP	A		B		C	
	mm	inch	mm	inch	mm	inch
3/8"	69	2.71	110	4.33	40	1.57
1/2"	72	2.83	112	4.41	40	1.57

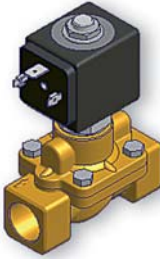

Dimensional Drawing N° 6

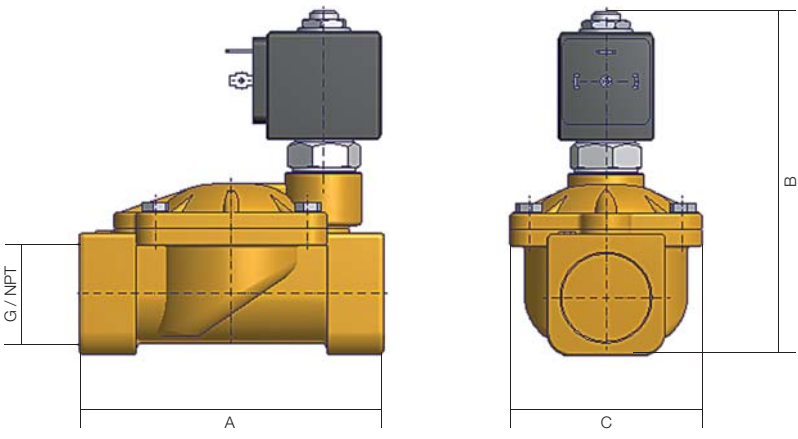

G NTP	A		B		C	
	mm	inch	mm	inch	mm	inch
3/4"	100	3.83	117.5	4.62	65	2.55
1"	104	4.09	113	4.84	65	2.55

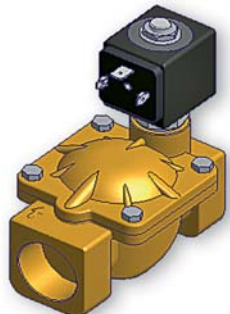

Dimensional Drawing N° 7

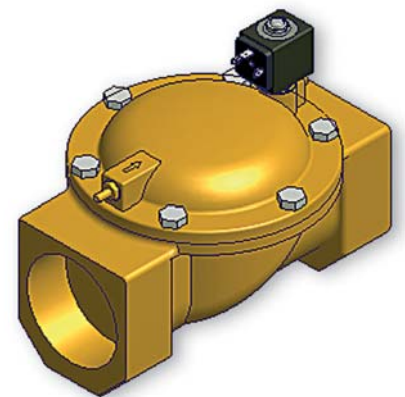
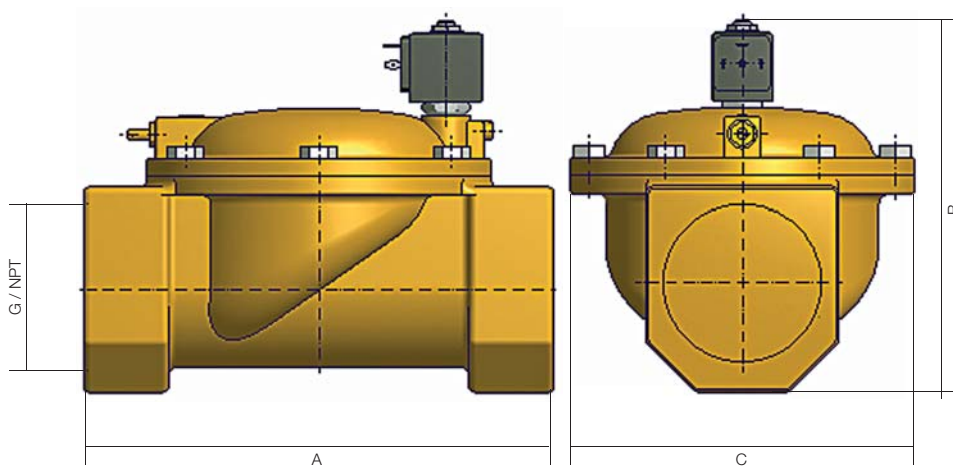

G NPT	A		B		C	
	mm	inch	mm	inch	mm	inch
1-1/4"	145	5.70	144.4	5.68	102	4.01
1-1/2"	145	-	134	-	102	-
2"	173	-	148	-	118	-

Dimensional Drawing N° 8

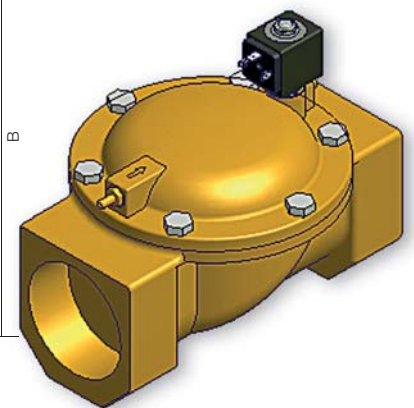
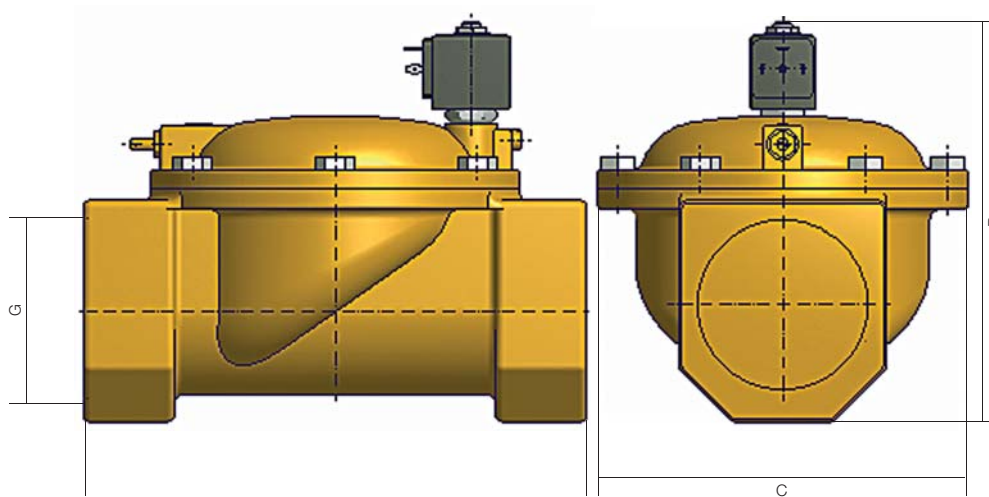

G	A		B		C	
	mm	inch	mm	inch	mm	inch
3/8"	245	-	195	-	184	-
1/2"	250	-	195	-	184	-

Dimensional Drawing N° 9

All dimensions are in mm

2/2 Normally Closed - NPT threads

NBR Seals (Max. Media Temp. 90°C)

Port Size NPT	Orifice		Flow Factors		Minimum Pressure		Maximum Differential		Weight		Description	Part Number	Dimensional Drawing
	mm	inch	m ³ /h	gpm	bar	PSI	bar	PSI	Kg	lbs			
3/8"	13	0.51	3.0	13.23	0.1	1.45	20	290	0.55	1.21	7321BIN90	444107W	1
1/2"	13	0.51	3.0	13.23	0.1	1.45	20	290	0.55	1.21	7321BAN90	444108W	1
3/4"	20	0.78	8.4	37.04	0.1	1.45	20	290	1.02	2.24	7321BCN90	444109W	2
1"	25	0.98	9.6	42.34	0.1	1.45	20	290	1.08	2.38	7321BDN90	444110W	2
1 1/4"	35	1.37	25.2	111.13	0.1	1.45	10	145	3.15	6.93	7321BEN90	444168W	3
1 1/2"	40	1.56	30.0	132.30	0.1	1.45	10	145	4.30	9.46	7321BFN90	444169W	3
2"	50	1.95	37.2	164.05	0.1	1.45	10	145	4.30	9.46	7321BGN90	444119W	3

Nominal pressure: 25 bar/360 PSI from 1 1/4" to 2" 16 bar/230 PSI

EPDM Seals (Max. Media Temp. 140°C)

Port Size NPT	Orifice		Flow Factors		Minimum Pressure		Maximum Differential		Weight		Description	Part Number	Dimensional Drawing
	mm	inch	m ³ /h	gpm	bar	PSI	bar	PSI	Kg	lbs			
3/8"	13	0.51	3.0	13.23	0.1	1.45	10	145	0.55	1.21	7321BIH90	444209W	1
1/2"	13	0.51	3.0	13.23	0.1	1.45	10	145	0.55	1.21	7321BAH90	444210W	1
3/4"	20	0.78	8.4	37.04	0.1	1.45	10	145	1.02	2.24	7321BCH90	444211W	2
1"	25	0.98	9.6	42.34	0.1	1.45	10	145	1.08	2.38	7321BDH90	444606W	2

Nominal pressure: 25 bar/360 PSI

2/2 Normally Open - NPT threads

NBR Seals (Max. Media Temp. 90°C)

Port Size NPT	Orifice		Flow Factors		Minimum Pressure		Maximum Differential		Weight		Description	Part Number	Dimensional Drawing
	mm	inch	m ³ /h	gpm	bar	PSI	bar	PSI	Kg	lbs			
3/8"	13	0.51	3.0	13.23	0.1	1.45	20	290	0.55	1.21	7322BIN90	444234W	6
1/2"	13	0.51	3.0	13.23	0.1	1.45	20	290	0.55	1.21	7322BAN90	444610W	6
3/4"	20	0.78	8.4	37.04	0.1	1.45	20	290	1.02	2.24	7322BCN90	444611W	7
1"	25	0.98	9.6	42.34	0.1	1.45	20	290	1.08	2.38	7322BDN90	444612W	7
1 1/4"	35	1.37	25.2	111.13	0.1	1.45	10	145	3.15	6.93	7322BEN90	444302W	8

EPDM Seals (Max. Media Temp. 140°C)

Port Size NPT	Orifice		Flow Factors		Minimum Pressure		Maximum Differential		Weight		Description	Part Number	Dimensional Drawing
	mm	inch	m ³ /h	gpm	bar	PSI	bar	PSI	Kg	lbs			
3/8"	13	0.51	3.0	13.23	0.1	1.45	10	145	0.55	1.21	7322BIH90	444613W	6
1/2"	13	0.51	3.0	13.23	0.1	1.45	10	145	0.55	1.21	7322BAH90	444614W	6
3/4"	20	0.78	8.4	37.04	0.1	1.45	10	145	1.02	2.24	7322BCH90	444615W	7
1"	25	0.98	9.6	42.34	0.1	1.45	10	145	1.08	2.38	7322BDH90	444616W	7
1 1/4"	35	1.37	25.2	111.13	0.1	1.45	10	145	3.15	6.93	7322BEH90	444576W	8

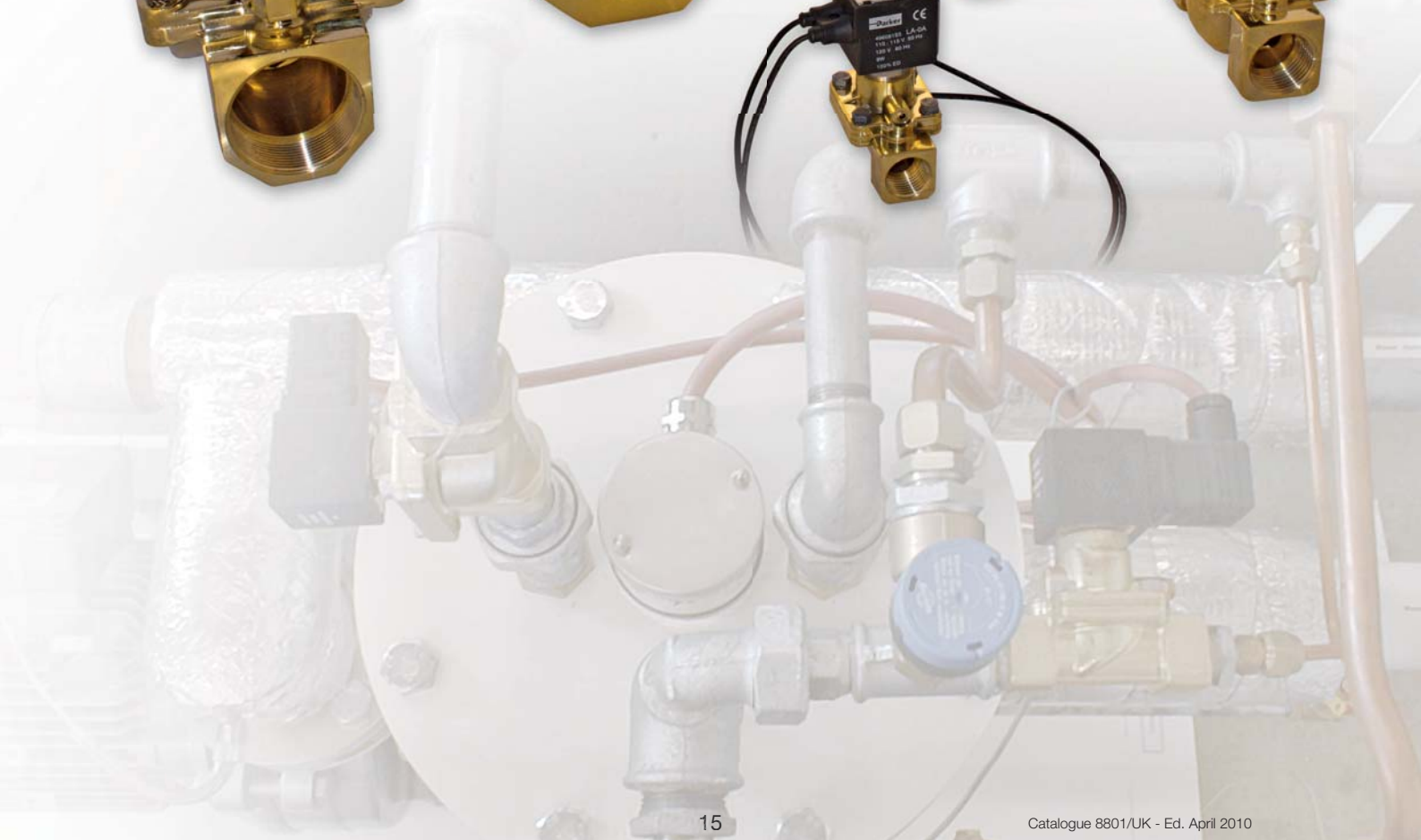

Electrical parts availability

Standard Coil Mono-Frequency, F class

Encapsulated in synthetic material, Connector for 2P + E DIN 43650 A Plug. IP65 rate can be achieved using a DIN Plug connector only.

Voltage	Power Consumption	Approvals	Description	Part Number	Dimensional Drawing
24/50	8 W	-	481865A2	439500	10
48/50	8 W	-	481865A4	439515	10
110/50	8 W	-	481865A5	439514	10
220-230/50	8 W	-	4818653D	439502	10
380/50	8 W	-	481865A9	439531	10
24/60	8 W	-	481865B2	439804	10
230/60	8 W	-	481865J3	439530	10
115/60	8 W	-	481865K8	439528	10
12 DC	9 W	-	481865C1	439508	10
24 DC	9 W	-	481865C2	439501	10
48DC	9 W	-	481865C4	439523	10
110V DC	9 W	-	481865C5	439532	10

Standard Coil Bi-Frequency, F class

Encapsulated in synthetic material, Connector for 2P + E DIN 43650 A Plug. IP65 rate can be achieved using a DIN Plug connector only.

Voltage	Power Consumption	Approvals	Description	Part Number	Dimensional Drawing
12/50-60	9 W	-	4835101W	439812	10
24/50-60	9 W	-	483510P0	439503	10
48/50-60	9 W	-	483510S4	439526	10
110-115/50 120/60	9 W	-	483510S5	439507	10
220-240/50 240/60	9 W	-	483510S6	439504	10

UL approved Coil, F class

Encapsulated in synthetic material, Connector for 2P + E DIN 43650 A Plug. IP65 rate can be achieved using a DIN Plug connector only.

Voltage	Power Consumption	Approvals	Description	Part Number	Dimensional Drawing
24/60	13 W	UL	491514B2	439511	10
24DC	16 W	UL/VDE	491514C2	439520	10
110/50 120/60	13 W	UL	491514P3	439512	10
220/50 240/60	13 W	UL	491514Q3	439513	10

H class Coil

(DC, AC 14W) encapsulated in synthetic material. Connection for 2P + E DIN 43650 A Plug. IP65 rate can be achieved using a DIN Plug connector only.

Voltage	Power Consumption	Approvals	Description	Part Number	Dimensional Drawing
24/50	14 W	-	492425A2	439550	10
110/50	14 W	-	492425A5	439551	10
230/50	14 W	-	492425F4	439518	10
24DC	14 W	-	492425C2	439522	10

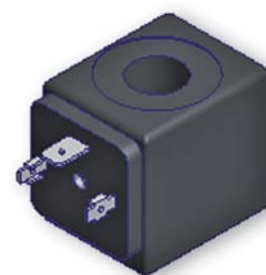
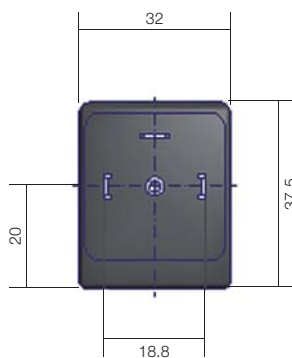
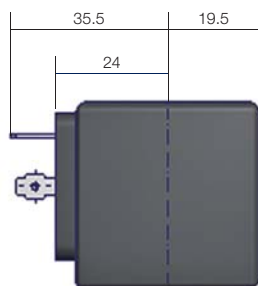

Dimensional Drawing N° 10

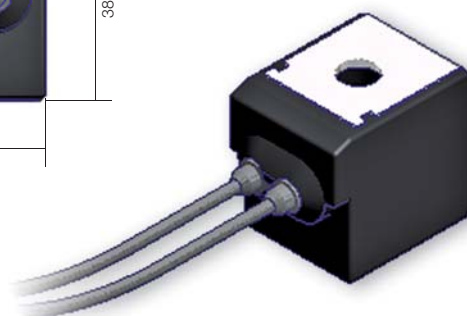
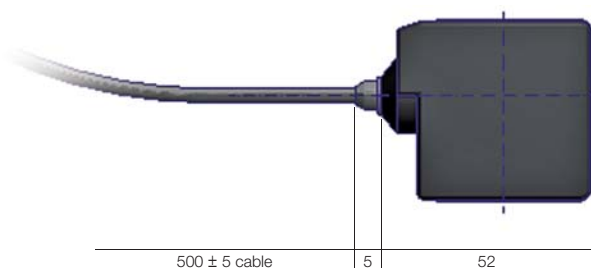

All dimensions are in mm

Dimensional Drawing N° 11

Electrical parts availability

IP67 Coil with two 500 mm flying leads, F class

Encapsulated in synthetic material. Protection rate IP67 as per DIN 40050.
Connection: 2 x 500 mm cables

Voltage	Power Consumption	Approvals	Description	Part Number	Dimensional Drawing
24/50 - 24/60	9 W	-	496081P0	439816	11
110-115/50 120/60	9 W	-	496081S5	439820	11
220-240/50 240/60	9 W	-	496081S6	439822	11
24DC	9 W	-	496081C2	439818	11
12DC	9 W	-	496081C1	439814	11

IP67 coil with two 500 mm flying leads, F class, UL approved

Encapsulated in synthetic material. Protection rate IP67 as per DIN 40050.
Connection: 2 x 500 mm cables

Voltage	Power Consumption	Approvals	Description	Part Number	Dimensional Drawing
24/60	13 W	UL	496082B2	439826	11
110/50 120/60	13 W	UL	496082P3	439828	11
208-240/60	14 W	UL	496082U3	439824	11
220/50 240/60	13 W	UL	496082Q3	439834	11
24DC	16 W	UL	496082C2	439832	11
12DC	16 W	UL	496082C1	439830	11

Explosion-proof EEx m II T4 (IP65)

Coil with housing integrated. Coil and magnetic circuit encapsulated in synthetic material.
The complete housing is supplied with an encapsulated connection cable (3 x 0.75 mm² section),
cable length is 3 000 mm with cable gland PG11. Power consumption: 8W AC, 9W DC.

Voltage	Power Consumption	Approvals	Description	Part Number	Dimensional Drawing
24DC	9 W	ATEX EEx m II 2GD	492670C2	492670C2	12
230/50	8 W	ATEX EEx m II 2GD	492670F4	492670F4	12

Explosion-proof II 2 G-EEx dm IIC T4

Coil/housing assembly encapsulated in synthetic material (H class). Protection degree: IP67.
Cable connection through cable gland M20x1.5 (DIN 46320).

Voltage	Power Consumption	Approvals	Description	Part Number	Dimensional Drawing
24DC	8 W	ATEX - EEx d mb IIC 2GD	495905C2	495905C2	13
48DC	8 W	ATEX - EEx d mb IIC 2GD	495905C4	495905C4	13
110DC	8 W	ATEX - EEx d mb IIC 2GD	495905C5	495905C5	13
24/50	8 W	ATEX - EEx d mb IIC 2GD	495905A2	495905A2	13
48/50	8 W	ATEX - EEx d mb IIC 2GD	495905A4	495905A4	13
240/60	8 W	ATEX - EEx d mb IIC 2GD	495905B8	495905B8	13
115/50	8 W	ATEX - EEx d mb IIC 2GD	495905E5	495905E5	13
230/50	8 W	ATEX - EEx d mb IIC 2GD	495905F4	495905F4	13
115/60	8 W	ATEX - EEx d mb IIC 2GD	495905K8	495905K8	13

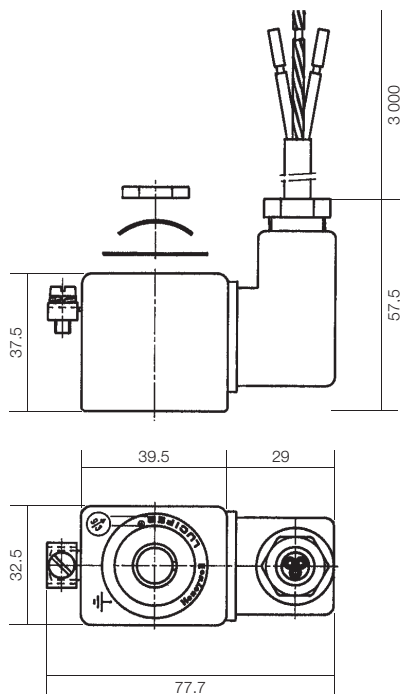

Dimensional Drawing N° 12

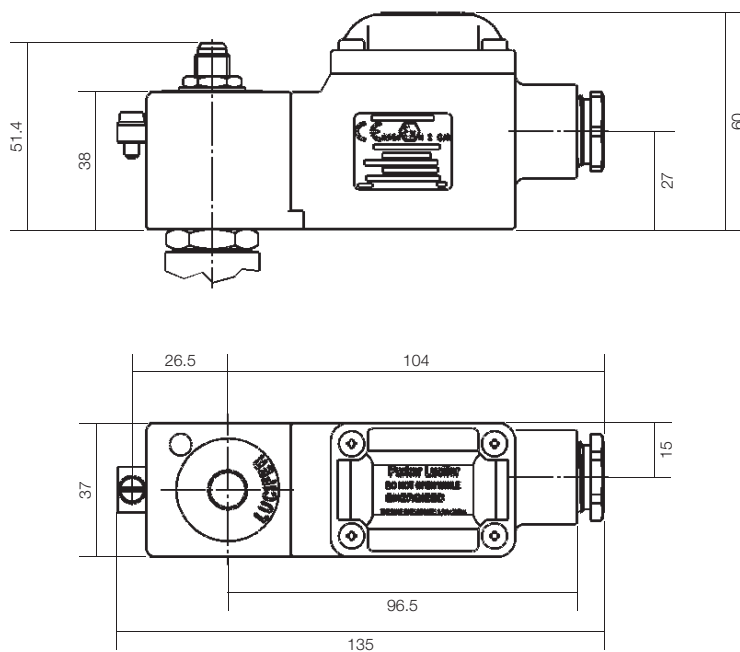

All dimensions are in mm

Dimensional Drawing N° 13

Accessories

Connector 2P + E DIN 43650 A

Max. A	Cable Section	Nominal Voltage	Description	Part Number	Drawing Reference
16 A	6-10 mm ²	250-/300 V =	PG9/PG11 DIN Connector	600003PLUG	14

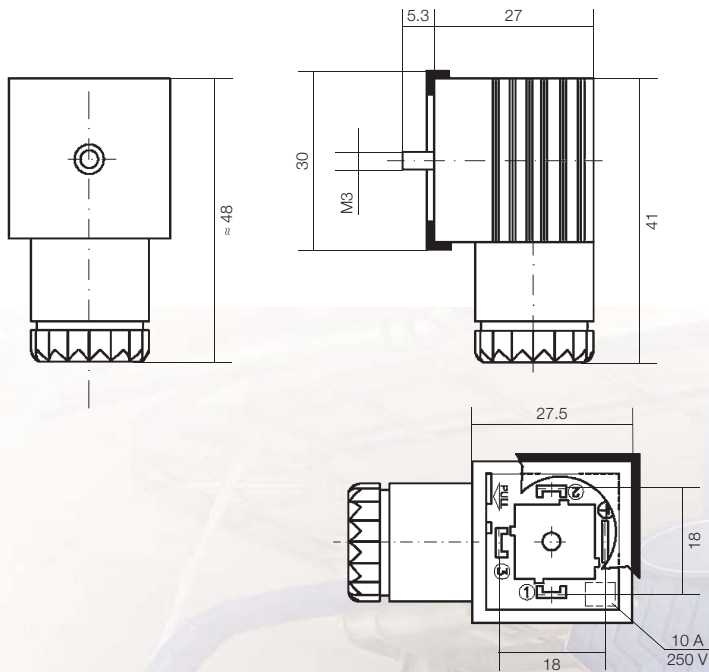

Drawing Reference N° 14

Spare Parts

Diaphragm Service Kit

This kit contains diaphragm only. Basing on port size of the valve and seals material required, please consult the prospect herebelow. Spare part kit is the same for Normally open and Normally closed versions.

Valve Port Size BSPP or NPT	Description	Part Number	Diaphragm Material
3/8" - 1/2"	Diaphragm 7321B/7322B N 3/8"-1/2"	306100SP	NBR
	Diaphragm 7321B/7322B V 3/8"-1/2"	306111SP	FKM
	Diaphragm 7321B/7322B H 3/8"-1/2"	306110SP	EPDM
3/4" - 1"	Diaphragm 7321B/7322B N 3/4"-1"	306120SP	NBR
	Diaphragm 7321B/7322B V 3/4"-1"	306131SP	FKM
	Diaphragm 7321B/7322B H 3/4"-1"	306130SP	EPDM
1 1/4" - 1 1/2"	Diaphragm 7321B/7322B N 1 1/4"-1 1/2"	306133SP	NBR
	Diaphragm 7321B/7322B H 1 1/4"-1 1/2"	306138SP	EPDM
2"	Diaphragm 7321B/7322B N 2"	306140SP	NBR
	Diaphragm 7321B/7322B H 2"	306150SP	EPDM
2 1/2" - 3"	Diaphragm 7321B/7322B N 2 1/2"-3"	306156SP	NBR

Rebuild Service Kit

This kit contains diaphragm, sleeve, plungers and seals. Basing on function, port size and seals material required, please consult the prospect herebelow. Spare part kit is not the same for Normally open and Normally closed versions.

Valve Port Size	Valve Fonction	Description	Part Number	Diaphragm Material
3/8" - 1/2"	NC	Rebuild Kit 7321B N - 3/8", 1/2", NBR	430088W	NBR
	NC	Rebuild Kit 7321B V - 3/8", 1/2", FKM	430090W	FKM
	NC	Rebuild Kit 7321B H - 3/8", 1/2", EPDM	430133W	EPDM
3/4" - 1"	NC	Rebuild Kit 7321B N - 3/4", 1", NBR	430089W	NBR
	NC	Rebuild Kit 7321B N - 1-1/4", 1-1/2", NBR	430095W	NBR
1 1/4" - 1 1/2"	NC	Rebuild Kit 7321B H - 1-1/4", 1-1/2", EPDM	430135W	EPDM
	NC	Rebuild Kit 7321B H - 2", NBR	430096W	NBR
2"	NC	Rebuild Kit 7321B H - 2", EPDM	430136W	EPDM
	NO	Rebuild Kit 7322B N - 3/8", 1/2", NBR	430137W	NBR
3/8" - 1/2"	NO	Rebuild Kit 7322B N - 3/8", 1/2", NBR	430137W	NBR
3/4" - 1"	NO	Rebuild Kit 7322B N - 3/4", 1", NBR	430138W	NBR
1 1/4" - 1 1/2"	NO	Rebuild Kit 7322B N - 1-1/4", 1-1/2", NBR	430139W	NBR
2"	NO	Rebuild Kit 7322B N - 2", NBR	430140W	NB

How to Order

Step 1

Select the pressure vessel catalogue number (description) and/or part number at pages 8 to 19.

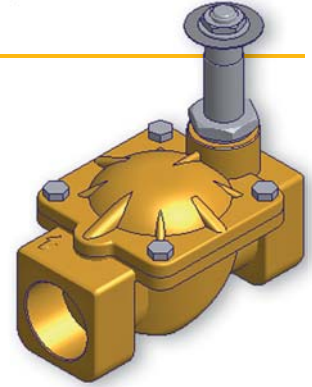

Step 2

Select the electrical part catalogue number and/or part number at pages 20 to 23.



Step 3

Select accessories at page 24.



Ordering a product or a configuration not listed in the catalogue

When an application demands a combination of features not listed in the catalog, use the significant description system indicated at page 7 to specify the exact valve needed. Parker FCDE personnel will assist in determining the applicability, availability and price of the new product.



WARNING - USER RESPONSIBILITY

FAILURE OR IMPROPER SELECTION OR IMPROPER USE OF THE PRODUCTS DESCRIBED HEREIN OR RELATED ITEMS CAN CAUSE DEATH, PERSONAL INJURY AND PROPERTY DAMAGE.

- This document and other information from Parker-Hannifin Corporation, its subsidiaries and authorized distributors provide product or system options for further investigation by users having technical expertise.
- The user, through its own analysis and testing, is solely responsible for making the final selection of the system and components and assuring that all performance, endurance, maintenance, safety and warning requirements of the application are met. The user must analyze all aspects of the application, follow applicable industry standards, and follow the information concerning the product in the current product catalog and in any other materials provided from Parker or its subsidiaries or authorized distributors.
- To the extent that Parker or its subsidiaries or authorized distributors provide component or system options based upon data or specifications provided by the user, the user is responsible for determining that such data and specifications are suitable and sufficient for all applications and reasonably foreseeable uses of the components or systems.

Parker's Motion & Control Technologies

At Parker, we're guided by a relentless drive to help our customers become more productive and achieve higher levels of profitability by engineering the best systems for their requirements. It means looking at customer applications from many angles to find new ways to create value. Whatever the motion and control technology need, Parker has the experience, breadth of product and global reach to consistently deliver. No company knows more about motion and control technology than Parker. For further info call 00800 27 27 5374.



AEROSPACE

Key Markets

- Aircraft engines
- Business & general aviation
- Commercial transports
- Land-based weapons systems
- Military aircraft
- Missiles & launch vehicles
- Regional transports
- Unmanned aerial vehicles

Key Products

- Flight control systems & components
- Fluid conveyance systems
- Fluid metering delivery & atomization devices
- Fuel systems & components
- Hydraulic systems & components
- Inert nitrogen generating systems
- Pneumatic systems & components
- Wheels & brakes



CLIMATE CONTROL

Key Markets

- Agriculture
- Air conditioning
- Food, beverage & dairy
- Life sciences & medical
- Precision cooling
- Processing
- Transportation

Key Products

- CO² controls
- Electronic controllers
- Filter driers
- Hand shut-off valves
- Hose & fittings
- Pressure regulating valves
- Refrigerant distributors
- Safety relief valves
- Solenoid valves
- Thermostatic expansion valves



ELECTROMECHANICAL

Key Markets

- Aerospace
- Factory automation
- Food & beverage
- Life science & medical
- Machine tools
- Packaging machinery
- Paper machinery
- Plastics machinery & converting
- Primary metals
- Semiconductor & electronics
- Textile
- Wire & cable

Key Products

- AC/DC drives & systems
- Electric actuators
- Controllers
- Gantry robots
- Gearheads
- Human machine interfaces
- Industrial PCs
- Inverters
- Linear motors, slides and stages
- Precision stages
- Stepper motors
- Servo motors, drives & controls
- Structural extrusions



FILTRATION

Key Markets

- Food & beverage
- Industrial machinery
- Life sciences
- Marine
- Mobile equipment
- Oil & gas
- Power generation
- Process
- Transportation

Key Products

- Analytical gas generators
- Compressed air & gas filters
- Condition monitoring
- Engine air, fuel & oil filtration & systems
- Hydraulic, lubrication & coolant filters
- Process, chemical, water & microfiltration filters
- Nitrogen, hydrogen & zero air generators



FLUID & GAS HANDLING

Key Markets

- Aerospace
- Agriculture
- Bulk chemical handling
- Construction machinery
- Food & beverage
- Fuel & gas delivery
- Industrial machinery
- Mobile
- Oil & gas
- Transportation
- Welding

Key Products

- Brass fittings & valves
- Diagnostic equipment
- Fluid conveyance systems
- Industrial hose
- PTFE & PFA hose, tubing & plastic fittings
- Rubber & thermoplastic hose & couplings
- Tube fittings & adapters
- Quick disconnects



HYDRAULICS

Key Markets

- Aerospace
- Aerial lift
- Agriculture
- Construction machinery
- Forestry
- Industrial machinery
- Mining
- Oil & gas
- Power generation & energy
- Truck hydraulics

Key Products

- Diagnostic equipment
- Hydraulic cylinders
- Hydraulic cylinders & accumulators
- Hydraulic motors & pumps
- Hydraulic systems
- Hydraulic valves & controls
- Power take-offs
- Rubber & thermoplastic hose & couplings
- Tube fittings & adapters
- Quick disconnects



PNEUMATICS

Key Markets

- Aerospace
- Conveyor & material handling
- Factory automation
- Food & beverage
- Life science & medical
- Machine tools
- Packaging machinery
- Transportation & automotive

Key Products

- Air preparation
- Compact cylinders
- Field bus valve systems
- Grippers
- Guided cylinders
- Manifolds
- Miniature fluidics
- Pneumatic accessories
- Pneumatic actuators & grippers
- Pneumatic valves and controls
- Rodless cylinders
- Rotary actuators
- Tie rod cylinders
- Vacuum generators, cups & sensors



PROCESS CONTROL

Key Markets

- Chemical & refining
- Food, beverage & dairy
- Medical & dental
- Microelectronics
- Oil & gas
- Power generation

Key Products

- Analytical sample conditioning products & systems
- Fluoropolymer chemical delivery fittings, valves & pumps
- High purity gas delivery fittings, valves & regulators
- Instrumentation fittings, valves & regulators
- Medium pressure fittings & valves
- Process control manifolds



SEALING & SHIELDING

Key Markets

- Aerospace
- Chemical processing
- Consumer
- Energy, oil & gas
- Fluid power
- General industrial
- Information technology
- Life sciences
- Military
- Semiconductor
- Telecommunications
- Transportation

Key Products

- Dynamic seals
- Elastomeric o-rings
- EMI shielding
- Extruded & precision-cut, fabricated elastomeric seals
- Homogeneous & inserted elastomeric shapes
- High temperature metal seals
- Metal & plastic retained composite seals
- Thermal management



ENGINEERING YOUR SUCCESS.

Parker Worldwide

AE - UAE, Dubai
Tel: +971 4 8127100
parker.me@parker.com

AR - Argentina, Buenos Aires
Tel: +54 3327 44 4129

AT - Austria, Wiener Neustadt
Tel: +43 (0)2622 23501-0
parker.austria@parker.com

AT - Eastern Europe, Wiener Neustadt
Tel: +43 (0)2622 23501 900
parker.easteurope@parker.com

AU - Australia, Castle Hill
Tel: +61 (0)2-9634 7777

AZ - Azerbaijan, Baku
Tel: +994 50 2233 458
parker.azerbaijan@parker.com

BE/LU - Belgium, Nivelles
Tel: +32 (0)67 280 900
parker.belgium@parker.com

BR - Brazil, Cachoeirinha RS
Tel: +55 51 3470 9144

BY - Belarus, Minsk
Tel: +375 17 209 9399
parker.belarus@parker.com

CA - Canada, Milton, Ontario
Tel: +1 905 693 3000

CH - Switzerland, Etoy
Tel: +41 (0)21 821 87 00
parker.switzerland@parker.com

CL - Chile, Santiago
Tel: +56 2 623 1216

CN - China, Shanghai
Tel: +86 21 2899 5000

CZ - Czech Republic, Klecany
Tel: +420 284 083 111
parker.czechrepublic@parker.com

DE - Germany, Kaarst
Tel: +49 (0)2131 4016 0
parker.germany@parker.com

DK - Denmark, Ballerup
Tel: +45 43 56 04 00
parker.denmark@parker.com

ES - Spain, Madrid
Tel: +34 902 330 001
parker.spain@parker.com

FI - Finland, Vantaa
Tel: +358 (0)20 753 2500
parker.finland@parker.com

FR - France, Contamine s/Arve
Tel: +33 (0)4 50 25 80 25
parker.france@parker.com

GR - Greece, Athens
Tel: +30 210 933 6450
parker.greece@parker.com

HK - Hong Kong
Tel: +852 2428 8008

HU - Hungary, Budapest
Tel: +36 1 220 4155
parker.hungary@parker.com

IE - Ireland, Dublin
Tel: +353 (0)1 466 6370
parker.ireland@parker.com

IN - India, Mumbai
Tel: +91 22 6513 7081-85

IT - Italy, Corsico (MI)
Tel: +39 02 45 19 21
parker.italy@parker.com

JP - Japan, Tokyo
Tel: +81 (0)3 6408 3901

KR - South Korea, Seoul
Tel: +82 2 559 0400

KZ - Kazakhstan, Almaty
Tel: +7 7272 505 800
parker.easteurope@parker.com

LV - Latvia, Riga
Tel: +371 6 745 2601
parker.latvia@parker.com

MX - Mexico, Apodaca
Tel: +52 81 8156 6000

MY - Malaysia, Shah Alam
Tel: +60 3 7849 0800

NL - The Netherlands, Oldenzaal
Tel: +31 (0)541 585 000
parker.nl@parker.com

NO - Norway, Ski
Tel: +47 64 91 10 00
parker.norway@parker.com

NZ - New Zealand, Mt Wellington
Tel: +64 9 574 1744

PL - Poland, Warsaw
Tel: +48 (0)22 573 24 00
parker.poland@parker.com

PT - Portugal, Leca da Palmeira
Tel: +351 22 999 7360
parker.portugal@parker.com

RO - Romania, Bucharest

Tel: +40 21 252 1382
parker.romania@parker.com

RU - Russia, Moscow
Tel: +7 495 645-2156
parker.russia@parker.com

SE - Sweden, Spånga
Tel: +46 (0)8 59 79 50 00
parker.sweden@parker.com

SG - Singapore
Tel: +65 6887 6300

SK - Slovakia, Banská Bystrica
Tel: +421 484 162 252
parker.slovakia@parker.com

SL - Slovenia, Novo Mesto
Tel: +386 7 337 6650
parker.slovenia@parker.com

TH - Thailand, Bangkok
Tel: +662 717 8140

TR - Turkey, Istanbul
Tel: +90 216 4997081
parker.turkey@parker.com

TW - Taiwan, Taipei
Tel: +886 2 2298 8987

UA - Ukraine, Kiev
Tel: +380 44 494 2731
parker.ukraine@parker.com

UK - United Kingdom, Warwick
Tel: +44 (0)1926 317 878
parker.uk@parker.com

US - USA, Cleveland
Tel: +1 216 896 3000

VE - Venezuela, Caracas
Tel: +58 212 238 5422

ZA - South Africa, Kempton Park
Tel: +27 (0)11 961 0700
parker.southafrica@parker.com

European Product Information Centre
Free phone: 00 800 27 27 5374
(from AT, BE, CH, CZ, DE, EE, ES, FI, FR, IE, IL, IS, IT, LU, MT, NL, NO, PT, SE, SK, UK)

© 2009 Parker Hannifin Corporation.
All rights reserved.



Parker Hannifin Ltd.
Tachbrook Park Drive
Tachbrook Park, Warwick CV34 6TU
United Kingdom
Tel.: +44 (0) 1926 317 878
Fax: +44 (0) 1926 317 855
parker.uk@parker.com
www.parker.com

Catalogue 8801/UK - 04/2010 - TMCZ

Your local authorized Parker distributor